

MP-3W SERIES STANDARD PORT 3-WAY BRASS BALL VALVES

BILL OF MATERIALS

PART #	NAME	MATERIAL	QTY
1	BODY	BRASS UNI 5705-65	1
2	ENDS	BRASS UNI 5705-65	3
3	BALL	BRASS UNI 5705-65 CHROME PLATED	1
4	SEAT	TFE	4
5	BODY SEAL	VITON	4
6	STEM SEAL	TFE	1
7	BODY O-RING	VITON	1
8	STEM O-RING	VITON	1
9	STEM NUT	BRASS UNI 5705-65	1
10	STEM	BRASS UNI 5705-65	1

VALVE FEATURES

- Standard port brass valve
- 1/4" through 2"
- Multiple flow configurations
- TFE® seats and seals
- Viton® body o-rings
- ISO mounting pad
- Blowout proof stem
- 4-seat design

PRESSURE RATING
600 PSI CWP
TEMPERATURE RATING
+297° F Maximum

NOTE: MAXIMUM TEMPERATURE RATING FOR STANDARD ACTUATORS IS 150° F (ELECTRIC) AND 180° (PNEUMATIC). SPECIAL SEALS OR HEAT EXTENSIONS ARE AVAILABLE FOR HIGH TEMPERATURE SERVICE.

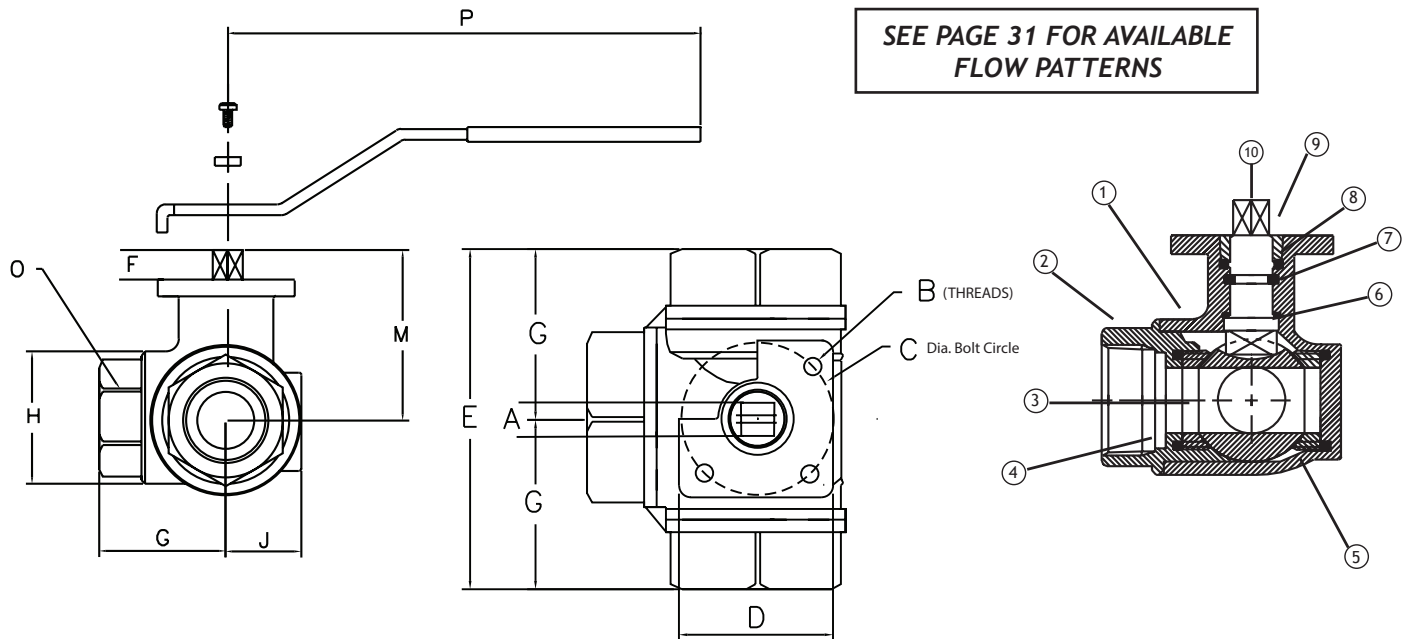

DIMENSIONAL DATA

SIZE	ISO 5211	A	B	C	D	E	F	G	H	J	M	O	P	CV	WT.
1/4"	F03	0.35	0.23	1.41	0.39	2.64	0.35	1.32	1.34	0.77	1.55	0.86	4.72	3.26	1.22
3/8"	F03	0.35	0.23	1.41	0.43	2.64	0.35	1.32	1.34	0.77	1.55	0.86	4.72	3.50	1.16
1/2"	F03	0.35	0.23	1.41	0.43	2.87	0.35	1.44	1.34	0.77	1.55	1.06	4.72	4.20	1.21
3/4"	F03	0.35	0.23	1.41	0.59	3.19	0.35	1.60	1.53	0.87	1.64	1.25	4.72	7.00	1.44
1"	F05	0.43	0.27	1.96	0.78	3.74	0.43	1.87	1.89	1.00	2.06	1.61	6.69	12.83	2.64
1-1/4"	F05	0.43	0.27	1.96	0.98	4.39	0.43	2.20	2.36	1.22	2.28	1.96	6.69	18.67	4.15
1-1/2"	F05	0.43	0.27	1.96	1.26	4.86	0.43	2.43	2.83	1.79	2.77	2.16	6.69	29.75	6.02
2"	F07	0.55	0.35	2.76	1.57	5.73	0.59	2.87	3.38	1.75	3.49	2.75	9.05	43.76	9.08
2-1/2"	F07	0.55	0.35	2.76	1.95	6.93	0.59	3.47	4.37	2.20	3.94	3.34	9.05	70.00	16.33
3"	F07	0.55	0.35	2.76	1.95	7.08	0.59	3.54	4.45	2.20	3.94	4.13	9.05	110	19.55

THE MANUAL VERSION OF THIS MODEL STARTS WITH AN "M"

ALL VALVES ARE 100% ELECTRONICALLY TESTED AT 80 PSI IN BOTH THE OPEN AND CLOSED POSITIONS