

STRAHMAN VALVES QUICK ACTION LINE BLINDS
SOLUTIONS FOR 100% POSITIVE PIPE & EQUIPMENT ISOLATION



 *Strahman*[®]

STRAHMAN LINE BLINDS

TABLE OF CONTENTS

Corporate Profile 2

What is a Line Blind? 3

Why Choose a Strahman Line Blind? 4

Line Blind Product Overview 5

Type 760S - Sliding & Non-Spreading Line Blind 6-7

Type 740S - Rotating & Non-Spreading Line Blind 8-9

Type 765S - Sliding & Non-Spreading Compact Line Blind 10-11

Type 770S - Enclosed & Non-Spreading Compact Line Blind 12-13

Type 700S - Rotating & Spreading Line Blind 14-15

Type 700S - Cryogenic Line Blind 15

Type 780S - Sliding & Non-Spreading Goggle Valve 16

Automated Blinds 17

Options and Applications 18-19

Seal Material and O-Ring Selection Guide 20

Customer Selection Guide 21

Anything's Possible...Just Ask!

Founded: 1921 in New York, USA

Locations:

- Strahman Valves, Inc., Bethlehem PA, USA
- Strahman Valves France, Mery France
- Strahman Valves Germany, Achern Germany
- BI-TORQ Valve Automation, La Fox IL, USA

Major Products:

- Line Blinds
- Cast & Fabricated Piston Type Drain, Sampling & Process Valves, Slab Gate Valves, Custom Made Valves
- Industrial Washdown Equipment
- Automated Valves & Fire Safe Products, Fusible Link Valves, Resettable Emergency Block Valves

Corporate Profile

Headquartered in Bethlehem, PA, Strahman Valves is a worldwide leader in the design and manufacture of the highest quality and best-performing valve products.

Operating through 4 divisions: Process Valve products, Washdown Equipment, Pre-Rinse Equipment and our BI-TORQ Division for valve automation and Fire Safe valve products, Strahman has earned a reputation for developing innovative solutions to complex problems. We engineer and manufacture our products with world-leading performance and value.

Strahman has become the standard for numerous market-leading customers in industries including oil and gas refining, chemical, petrochemical, polymer, pulp and paper, mining, biotechnology, pharmaceutical, food processing, beverage, dairy and commercial food serving.

***Strahman pioneered the development of quick action Line Blinds.
Although our unique designs have been copied by many, nothing beats the original!***



Strahman Corporate Headquarters
Bethlehem, Pennsylvania, USA



Strahman Valves
Mery, France

What is a Lind Blind?

A Line Blind is a safety device that is used to Shut Off (or blind off) the product flow in a process pipe. This is done to isolate a piece of process pipe, or equipment such as storage tanks. Isolating with a Line Blind provides a 100% positive shut-off, which can be visually checked by maintenance staff so that work can be safely done downstream from the Line Blind.

The typical configuration for line isolation is to use a block valve with a Line Blind downstream from the block valve. Isolation valves can leak, therefore causing an unsafe and dangerous situation. The use of a Line Blind to guarantee 100% positive shut-off.

Traditional methods to shut off a process line can be dangerous and are time consuming to carry out. The chart below illustrates the advantages of a Line Blind versus traditional pipe isolation using blind plates.

PIPE SIZE	BLINDING TECHNIQUE		SAVINGS EFFECT
	SPECTACLE PLATE	STRAHMAN LINE BLIND	
½" - 12"	Time: 1-4 hrs. Personnel: 2-4 people Resources: tools, gaskets, pipe wedge, equipment	Time: 30 sec. or less Personnel: 1 person Resources: none	<ul style="list-style-type: none"> • 2-16 man-hours • Gaskets, tools, fasteners, equipment • Safety
14" - 48"	Time: 1-12 hrs. Personnel: 4-10 people Resources: tools, gaskets, equipment	Time: 30 sec. -3 minutes Personnel: 1 person Resources: none	<ul style="list-style-type: none"> • 16-20 man-hours • Gaskets, tools, fasteners, equipment • safety



BI-TORQ Valve Automation
LA Fox, Illinois, USA



Strahman Valves
Achern, Germany



WHY Choose a Strahman Line Blind?

Strahman offers one of the largest range of Line Blinds considering choice of design, size, materials, flexibility to meet special technical requirements and quick delivery needs.

From cryogenic solutions to high temperature and high pressure designs, Strahman offers a wide range of Line Blind designs. We developed a line of unique, quick action Line Blinds that combine ease-of-use with the ultimate in operator safety.

To best serve our customers, Strahman stocks Line Blinds from 1/2" (DN15) to 24" (DN600) in 150 lb. and 300 lb. pressure classes so quick deliveries are no problem.

Strahman Line Blinds offer the following features:

No matter your problem or application, Strahman Valves has the solution.

- 100% positive line isolation and ZERO leakage
- Safe, easy and fast blinding by any operator. (30 sec. to 5 minutes / one person)
- No line spreading required to change spectacle plate due to unique non-spreading Cam design. Therefore, zero pipe stress during change of spectacle plate.
- Cost savings due to one man operation (see table page 5) and the fact that no tools such as cranes, bolts, nuts etc. are required.
- Auto positioning of the spectacle plate
- Seal rings easy to change
- Non-spreading Cam system offers friction free spectacle movement protecting and increasing seal ring lifetime
- Optional locking devices in various designs available
- Optional gasket protection plates available
- Use of easy to get, standard O-rings
- Optional automation available (electric, air cylinders, air motors, hydraulic)
- Optional drain valve available.

Strahman Line Blind Product Line

TYPE 760S - Sliding & Non-Spreading



TYPE 740S - Rotating and Non-Spreading



Type 765S - Compact Sliding & Non-Spreading

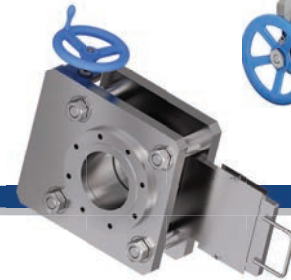

TYPE 770S - Enclosed & Non-Spreading

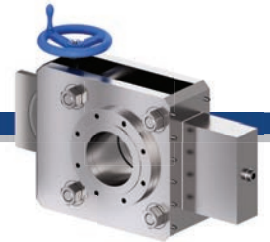

TYPE 700S - Rotating & Spreading



TYPE 780S - Sliding & Non-Spreading Goggle Valves

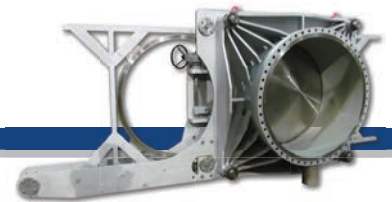

Automated Line Blinds



TYPE 760S

Sliding & Non-Spreading Line Blind

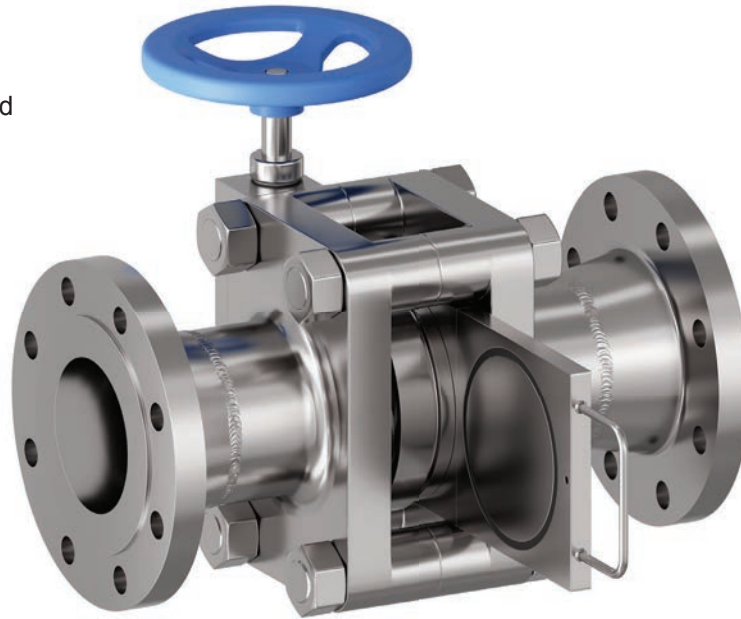

Features

One operator turns the handwheel, which activates the unique Cam-Gear System within the body flanges of the Line Blind. The Cam-Gear System creates the space to change the spectacle plate without changing the face-to-face of the Line Blind. This eliminates spreading the piping in which the Blind is installed (**Non-Spreading**). The spectacle plate can then be moved by **sliding** it to the open or closed Position. Sliding the plate is safe and effortless. The complete blinding procedure takes from 30 seconds to 3 minutes max. (Depending on the unit size) to complete: turn the handwheel open, **slide** the spectacle plate, and close the unit with the handwheel.

Technical Specifications

NOMINAL DIAMETER

- NPS1/2 (DN15) - NPS100 (DN2500)

PRESSURE RATING

- ASME Class 150 to Class 1500
- Other pressure classes up to ASME 2500 are available upon request.

FUNCTION

- Perfect Gas and Liquid Isolation (ZERO Leakage)

TEMPERATURE RANGE

- Standard Design: -20°C ~ +200°C
- High Temp. Design: +200°C ~ +816°C
- Cryogenic Design: -196°C

MATERIALS

- Body: Carbon Steel, Stainless Steel, Special Material (Duplex, Hastelloy, Monel, Inconel, etc.)
- Blind: Stainless Steel, Special Material (Duplex, Hastelloy, Monel, Inconel, etc.)
- Moving Parts & Sealing Surface are Anti-Corrosion Materials

METHOD OF OPERATION

- Manual Operation
- Electric, Pneumatic or Hydraulic Operation

Common Applications

REFINERY

- Catalyst Service
- Decoking Line
- FCCU Fractionator isolation
- Flare Gas Line
- Ethylene Furnace
- Steam and Vapor Line

CHEMICAL PLANT

- Chemical Cleaning Isolation
- Filtration Systems
- Loading Stations
- Mixing Lines
- Reactor Blowdown
- Regeneration Gas Line
- Transfer Line

OFFSHORE

- FPSO
- LNG Ship
- Inert Gas System
- Shipboat lines
- Vessel Inlet

STEEL

- Coke Oven Gas
- Blast Furnace Gas

Non-Spreading Sliding Type Cam Blind Series 760S, Product Code LTC

Please see our animation at www.strahmanvalves.com

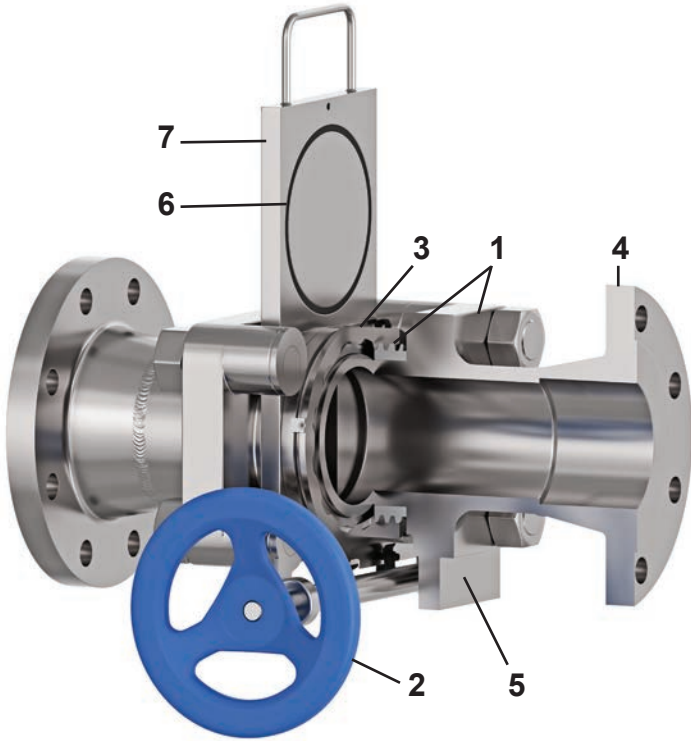

1. The Line Blind is simply operated by turning the hand wheel. The special Cam system creates space in-between the body flanges allowing the spectacle plate to rotate to the open or close position. The unique worm cam pushes **AND** retracts the seal rings to and from the spectacle plate. Spreading of the process pipe flanges is **NOT** required. Therefore actuating the blind does not apply stress to the process pipe in which the blind is installed. Face to Face of the Line Blind **NEVER** changes.
2. Hand wheel for spindle actuation. Gear box, electric and pneumatic actuation available. Optional locking device is available (see right).
3. Seal carrier that holds seal ring to atmosphere
4. End connections can be Flanged or Butt Weld ends
5. Body of a quick action line blind. Available in a wide range of materials.
6. Seal rings are mounted on the spectacle plate for easy exchange in case of maintenance. Strahman offers O-rings and flat type gaskets for low temperatures. Double O-ring arrangements are available. For high temperatures Strahman offers high temperature graphite and metal to metal sealing materials.
7. Spectacle plate is made from stainless steel material as a standard.

Non-Spreading Swing Type Cam Blind Series 760S

Standard Product Range Chart - Other size and pressure class combinations upon request.

Please let us know your requirement!

Class	Type	Size													
		Inches	½-6	8	10	12	14	16	18	20	24	28	32	36	40
ANSI/ DIN	DN (mm)	15-150	200	250	300	350	400	450	500	600	700	800	900	1000	1200
150 lbs/ PN10/16/20	760 Series	•	•	•	•	•	•	•	•	•	•	•	•		
300 lbs/ PN25/40/50	760 Series	•	•	•	•	•	•	•	•	•	•	•	•		
600 lbs/ PN100	760 Series	•	•	•	•	•	•								
900 lbs/ PN150	760 Series	•	•	•	•										
1500 lbs/ PN250	760 Series	•													

TYPE 740S

Rotating & Non-Spreading Line Blind

Features

One operator turns the handwheel, which activates the unique Cam-Gear System within the body flanges of the Line Blind. The Cam-Gear System creates the space to change the spectacle plate without changing the face-to-face of the Line Blind. This eliminates spreading the piping in which the Blind is installed (**Non-Spreading**). The spectacle plate can then be moved by **rotating** it to the open or closed Position. Sliding the plate is safe and effortless. The complete blinding procedure takes from 30 seconds to 3 minutes max. (Depending on the unit size) to complete: turn the handwheel open, **rotate** the spectacle plate, and close the unit with the handwheel.



Technical Specifications

NOMINAL DIAMETER

- NPS ½ (DN15) - NPS 36" (DN900)

PRESSURE RATING

- ASME Class 150 to Class 1500
- Other pressure classes up to ASME 2500 are available upon request.

FUNCTION

- Perfect Gas and Liquid Isolation (ZERO Leakage)

TEMPERATURE RANGE

- Standard Design: -20°C ~ +200°C
- High Temp. Design: +200°C ~ +816°C
- Cryogenic Design: -196°C

MATERIALS

- Body: Carbon Steel, Stainless Steel, Special Material (Duplex, Hastelloy, Monel, Inconel, etc.)
- Blind: Stainless Steel, Special Material (Duplex, Hastelloy, Monel, Inconel, etc.)
- Moving Parts & Sealing Surface are Anti-Corrosion Materials

METHOD OF OPERATION

- Manual Operation
- Electric, Pneumatic or Hydraulic Operation

Common Applications

REFINERY

- Decoking Line
- Flare Gas Line
- Ethylene Furnace
- Steam and Vapor Line

CHEMICAL PLANT

- Chemical Cleaning Isolation
- Filtration Systems
- Mixing Lines
- Reactor Blowdown
- Regeneration Gas Line

OFFSHORE

- FPSO
- LNG Ships
- Inert Gas System
- Shipboat lines
- Vessel Inlet

STEEL

- Coke Oven Gas
- Blast Furnace Gas

Non-Spreading Rotating Type Cam Blind Series 740S, Product Code LRC

Please see our animation at www.strahmanvalves.com

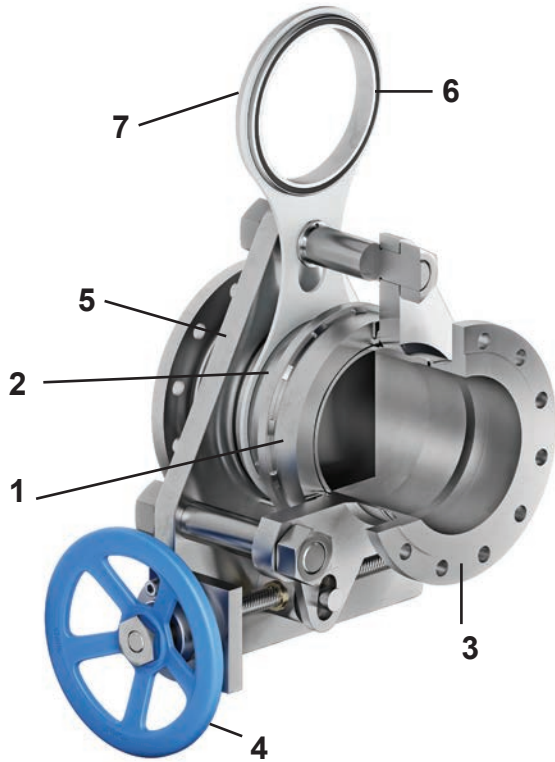

1. The Line Blind is simply operated by turning the hand wheel. The special Cam system creates space in-between the body flanges allowing the spectacle plate to rotate to the open or close position. The unique worm cam pushes **AND** retracts the seal rings to and from the spectacle plate. Spreading of the process pipe flanges is **NOT** required. Therefore actuating the blind does not apply stress to the process pipe in which the blind is installed. Face to Face of the Line Blind **NEVER** changes.
2. Seal carrier that holds seal ring to atmosphere
3. End connections can be Flanged or Butt Weld ends
4. Hand wheel for spindle actuation.
Gear box, electric and pneumatic actuation available.
Optional locking device is available.
5. Body of a quick action line blind. Available in a wide range of materials.
6. Seal rings are mounted on the spectacle plate for easy exchange in case of maintenance. Strahman offers O-rings and flat type gaskets for low temperatures. Double O-ring arrangements are available. For high temperatures Strahman offers high temperature graphite and metal to metal sealing materials.
7. Spectacle plate is made from stainless steel material as a standard.

Non-Spreading Rotating Type Cam Blind Series 740S

Standard Product Range Chart

Class	Type	Size													
		Inches	½-6	8	10	12	14	16	18	20	24	28	32	36	40
ANSI/ DIN	DN (mm)	15-150	200	250	300	350	400	450	500	600	700	800	900	1000	1200
150 lbs/ PN10/16/20	740 Series	•	•	•	•	•	•	•	•	•	•	•	•		
300 lbs/ PN25/40/50	740 Series	•	•	•	•	•	•	•	•	•	•	•	•		
600 lbs/ PN100	740 Series	•	•	•	•	•	•								
900 lbs/ PN150	740 Series	•	•	•	•										
1500 lbs/ PN250	740 Series	•													

TYPE 765S

Compact Sliding & Non-Spreading Line Blind



Features

One operator turns the handwheel, which activates the unique Cam-Gear System within the body flanges of the Line Blind. The Cam-Gear System creates the space to change the spectacle plate without changing the face-to-face of the Line Blind. This eliminates spreading the piping in which the Blind is installed (**Non-Spreading**). The spectacle plate can then be moved by **sliding** it to the open or closed Position. Sliding the plate is safe and effortless. The complete blinding procedure takes from 30 seconds to 3 minutes max. (Depending on the unit size) to complete: turn the handwheel open, **slide** the spectacle plate, and close the unit with the handwheel. The Studded Flanges allow a short face-to-face dimension, making the design very compact. This Line Blind type is ideal for applications with a space restriction. The compact design also reduces weight, and therefore the requirement for extra process pipe support.

Technical Specifications

NOMINAL DIAMETER

- NPS1/2 (DN15) - NPS100 (DN2500)

PRESSURE RATING

- ASME Class 150 to Class 1500
- Other pressure classes up to ASME 2500 are available upon request.

FUNCTION

- Perfect Gas and Liquid Isolation (ZERO Leakage)

TEMPERATURE RANGE

- Standard Design: -20°C ~ +200°C
- High Temp. Design: +200°C ~ +816°C
- Cryogenic Design: -196°C

MATERIALS

- Body: Carbon Steel, Stainless Steel, Special Material (Duplex, Hastelloy, Monel, Inconel, etc.)
- Blind: Stainless Steel, Special Material (Duplex, Hastelloy, Monel, Inconel, etc.)
- Moving Parts & Sealing Surface are Anti-Corrosion Materials

METHOD OF OPERATION

- Manual Operation
- Electric, Pneumatic or Hydraulic Operation

Common Applications

REFINERY

- Decoking Line
- Flare Gas Line
- Ethylene Furnace
- Steam and Vapor Line
- FCCU Fractionator Isolation (overhead & bottom line)
- Catalyst Service

CHEMICAL PLANT

- Chemical Cleaning Isolation
- Filtration Systems
- Mixing Lines
- Reactor Blowdown
- Regeneration Gas Line
- Ethylene Furnace
- Loading Station
- Transfer Line

OFFSHORE

- Pump Isolation
- LNG Tank
- Airport Fuel Line
- Oil & Chemical Tank farm
- Loading Station

STEEL

- Coke Oven Gas
- Blast Furnace Gas

Non-Spreading COMPACT Sliding Type Cam Blind Series 765S, Product Code LRC

Please see our animation at www.strahmanvalves.com

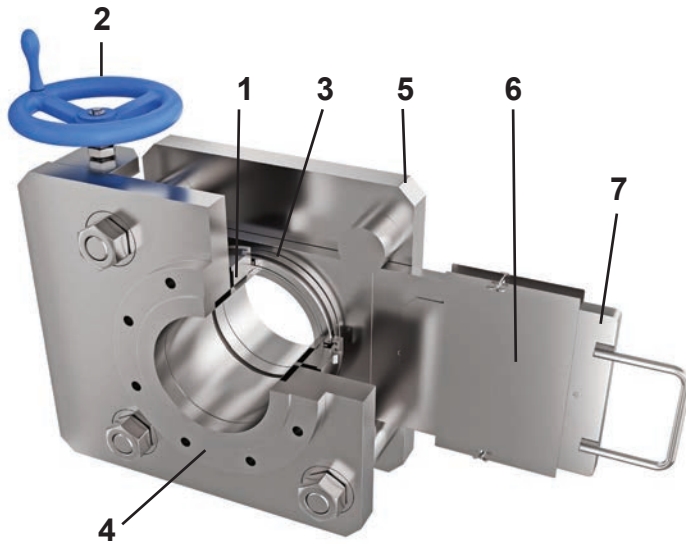

1. The Line Blind is simply operated by turning the hand wheel. The special Cam system creates space in-between the body flanges allowing the spectacle plate to rotate to the open or close position. The unique worm cam pushes **AND** retracts the seal rings to and from the spectacle plate. Spreading of the process pipe flanges is **NOT** required. Therefore actuating the blind does not apply stress to the process pipe in which the blind is installed. Face to Face of the Line Blind **NEVER** changes.
4. Hand wheel for spindle actuation.
Gear box, electric and pneumatic actuation available.
Optional locking device is available.
2. Seal carrier that holds seal ring to atmosphere
3. End connections are Studded Flanges to allow for COMPACT design.
5. Body of a quick action line blind. Available in a wide range of materials.
6. Seal rings are mounted on the spectacle plate for easy exchange in case of maintenance. Strahman offers O-rings and flat type gaskets for low temperatures. Double O-ring arrangements are available. For high temperatures Strahman offers high temperature graphite and metal to metal sealing materials. (Seal rings cover by SSTL protection plate on this image)
7. Spectacle plate is made from stainless steel material as a standard.

Non-Spreading Swing Type Cam Blind Series 765S

Standard Product Range Chart

Class	Type	Size													
		Inches	½-6	8	10	12	14	16	18	20	24	28	32	36	40
ANSI/ DIN	DN (mm)	15-150	200	250	300	350	400	450	500	600	700	800	900	1000	1200
150 lbs/ PN10/16/20	765 Series	•	•	•	•	•	•	•	•	•	•	•	•		
300 lbs/ PN25/40/50	765 Series	•	•	•	•	•	•	•	•	•	•	•	•		
600 lbs/ PN100	765 Series	•	•	•	•	•	•								
900 lbs/ PN150	765 Series	•	•	•	•										
1500 lbs/ PN250	765 Series	•													

TYPE 770S

Enclosed Sliding & Non-Spreading Line Blind

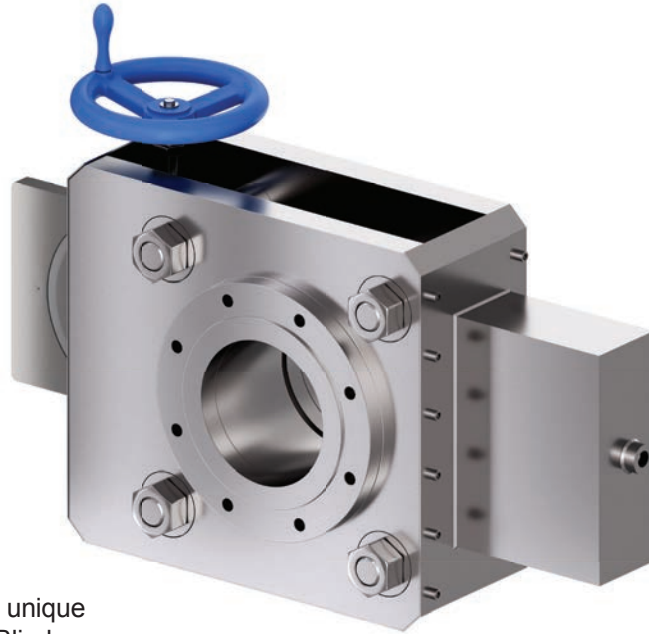

Features

One operator turns the handwheel, which activates the unique Cam-Gear System within the body flanges of the Line Blind.

The Cam-Gear System creates the space to change the spectacle plate without changing the face-to-face of the Line Blind. This eliminates spreading the piping in which the Blind is installed (**Non-Spreading**). The spectacle plate will then be **removed and exchanged** from the unit, placing a second spectacle plate with the opposite position (open = plate with hole; closed = solid plate). The complete blinding procedure takes from 30 seconds to 3 minutes max. (Depending on the unit size) to complete: turn the handwheel open, **exchange** the spectacle plate and close the unit. Depending on the installation position on the blind, a one plate design as shown can be offered. The Studded Flanges allow a short face-to-face dimension, making the design very compact. This Line Blind type is ideal for applications with a space restriction. Three sides of the Line Blind body are closed to prevent spillage during the blinding process.

Technical Specifications

NOMINAL DIAMETER

- NPS1/2 (DN15) - NPS100 (DN2500)

PRESSURE RATING

- ASME Class 150 to Class 1500
- Other pressure classes up to ASME 2500 are available upon request.

FUNCTION

- Perfect Gas and Liquid Isolation (ZERO Leakage)

TEMPERATURE RANGE

- Standard Design: -20°C ~ +200°C
- High Temp. Design: +200°C ~ +816°C
- Cryogenic Design: -196°C

MATERIALS

- Body: Carbon Steel, Stainless Steel, Special Material (Duplex, Hastelloy, Monel, Inconel, etc.)
- Blind: Stainless Steel, Special Material (Duplex, Hastelloy, Monel, Inconel, etc.)
- Moving Parts & Sealing Surface are Anti-Corrosion Materials

METHOD OF OPERATION

- Manual Operation
- Electric, Pneumatic or Hydraulic Operation

Common Applications

OIL TERMINAL

- Pump Isolation
- LNG Tank
- Airport Fuel Line
- Oil & Chemical Tank farm
- Loading Station

OFFSHORE

- FSPO
- LNG Transfer
- Shipboard Lines
- Vessel Inlet
- Inert Gas System

ENCLOSED & Non-Spreading Cam Blind Series 770S, Product Code LRE

Please see our animation at www.strahmanvalves.com

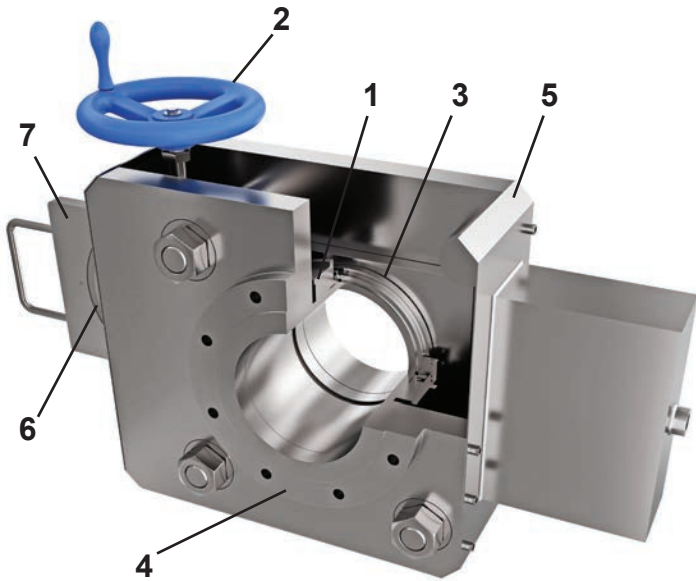

1. The Line Blind is simply operated by turning the hand wheel. The special Cam system creates space in-between the body flanges allowing the spectacle plate to rotate to the open or close position. The unique worm cam pushes **AND** retracts the seal rings to and from the spectacle plate. Spreading of the process pipe flanges is **NOT** required. Therefore actuating the blind does not apply stress to the process pipe in which the blind is installed. Face to Face of the Line Blind **NEVER** changes. Three Body sides are closed which avoids product spillage while blinding. The unit uses 2 individual spectacle plates; one for the open position (with hole) and one for the closed position (solid).
2. Handwheel for spindle actuation. Gear box, electric and pneumatic actuation available. Optional locking device is available.
3. Seal carrier that holds seal ring to atmosphere
4. End connections can be Flanged, Studded flanges or Butt Weld ends
5. Body of a quick action line blind. Available in a wide range of materials.
6. Seal rings are mounted on the spectacle plate for easy exchange in case of maintenance. Strahman offers O-rings and flat type gaskets for low temperatures. Double O-ring arrangements are available. For high temperatures Strahman offers high temperature graphite and metal to metal sealing materials.
7. Spectacle plate is made from stainless steel material as a standard.

Non-Spreading Swing Type Cam Blind Series 770S

Standard Product Range Chart

Class	Type	Size													
		Inches	½-6	8	10	12	14	16	18	20	24	28	32	36	40
ANSI/ DIN	DN (mm)	15-150	200	250	300	350	400	450	500	600	700	800	900	1000	1200
150 lbs/ PN10/16/20	770S Series	•	•	•	•	•	•	•	•	•	•	•	•		
300 lbs/ PN25/40/50	770S Series	•	•	•	•	•	•	•	•	•	•	•	•		
600 lbs/ PN100	770S Series	•	•	•	•	•	•								
900 lbs/ PN150	770S Series	•	•	•	•										
1500 lbs/ PN250	770S Series	•													

TYPE 700S

Rotating & Spreading Line Blind



Features

This is the original design for a quick action Line Blind. Depending on the size, 3 to 7 Jack Bolts are being turned to spread the unit, and therefore spread the process pipe. This creates the space to **rotate** the spectacle plate. By turning the Jack Bolts to the closed position, the unit will seal again.

Technical Specifications

NOMINAL DIAMETER

- NPS1/2" (DN15) - NPS24" (DN600)

PRESSURE RATING

- ASME Class 150 to Class 1500
- Other pressure classes up to ASME 2500 are available upon request.

FUNCTION

- Perfect Gas and Liquid Isolation (ZERO Leakage)

TEMPERATURE RANGE

- -40°C ~ +816°C

MATERIALS

- Body: Carbon Steel, Stainless Steel, Special Material (Duplex, Hastelloy, Monel, Inconel, etc.)
- Blind: Stainless Steel, Special Material (Duplex, Hastelloy, Monel, Inconel, etc.)
- Moving Parts & Sealing Surface are Anti-Corrosion Materials

METHOD OF OPERATION

- Manual Operation
- Electric, Pneumatic or Hydraulic Operation

Common Applications

REFINERY

- Ethylene Furnace
- Decoking Line
- Steam & Vapor Line
- Catalyst Service
- Flare Gas Line
- FCCU Fractionator Isolation (overhead & bottom line)

CHEMICAL PLANT

- Reactor Blowdown
- Ethylene Furnace
- Mixing Lines
- Filtration System
- Chemical Cleaning Isolation
- Regeneration Gas Line
- Loading Station

OFFSHORE

- FSPO
- LNG Ship
- Shipboard Lines
- Vessel Inlet
- Inert Gas System

STEEL

- Coke Oven Gas
- Blast Furnace Gas

POWER PLANT

- Coke Oven Gas

Spreading & Rotating Type Blind Series 700S, Product Code LRS

Please see our animation at www.strahmanvalves.com



Cryogenic Line Blinds

Strahman Valves has developed and qualified a complete range of line blinds for Cryogenic applications. These line blinds have **Lloyd's Register type approval** for blinding applications of pipelines on LNG service for marine and off-shore installations.

Strahman's approval certificate number is **02/00070**.

The qualified product is our Series 700.

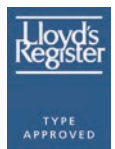

TYPE 780S

Sliding & Non-Spreading Goggle Valve

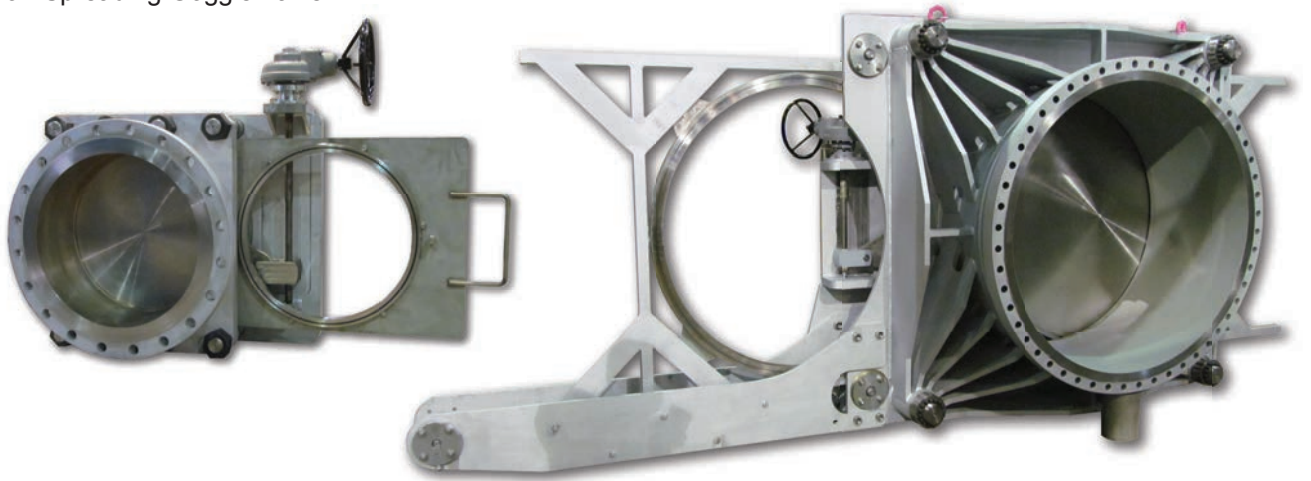

Features

One operator turns the Gear Box, which activates the unique Cam-Gear System within the body flanges of the Lind Blind. The Cam-Gear System creates the space to change the spectacle plate without changing the face-to-face of the Goggle Valve. This eliminates spreading the piping in which the Blind is installed (**Non-Spreading**). The spectacle plate will then be moved by **sliding** it to the open or closed position. Sliding the plate is safe and effortless. The complete blinding procedure takes from 30 seconds to 3 minutes max. (Depending on the unit size) to complete: turn the handwheel open, **slide** the spectacle plate and close the unit with the Gear Box. The actuation of the Cam system as well as the Spectacle plate can be Manual or Automatic (electric motor, air cylinder, air motor, hydraulic).

Technical Specifications

NOMINAL DIAMETER

- NPS24 (DN600) - NPS100 (DN2500)

PRESSURE RATING

- ASME Class 150 to Class 1500

FUNCTION

- Perfect Gas and Liquid Isolation (ZERO Leakage)

TEMPERATURE RANGE

- Standard Design: -20°C ~ +200°C
- High Temp. Design: +200°C ~ +816°C
- Cryogenic Design: -196°C

MATERIALS

- Body: Carbon Steel, Stainless Steel, Special Material (Duplex, Hastelloy, Monel, Inconel, etc.)
- Blind: Stainless Steel, Special Material (Duplex, Hastelloy, Monel, Inconel, etc.)
- Moving Parts & Sealing Surface are Anti-Corrosion Materials

METHOD OF OPERATION

- Manual Operation
- Electric, Pneumatic or Hydraulic Operation

Common Applications

STEEL

- Coke Oven Gas
- Blast Furnace Gas

REFINERY

- Flare Gas Line
- LPG

CHEMICAL PLANT

- Chemical Cleaning Isolation
- Filtration System
- Transfer Line

AUTOMATED LINE BLINDS

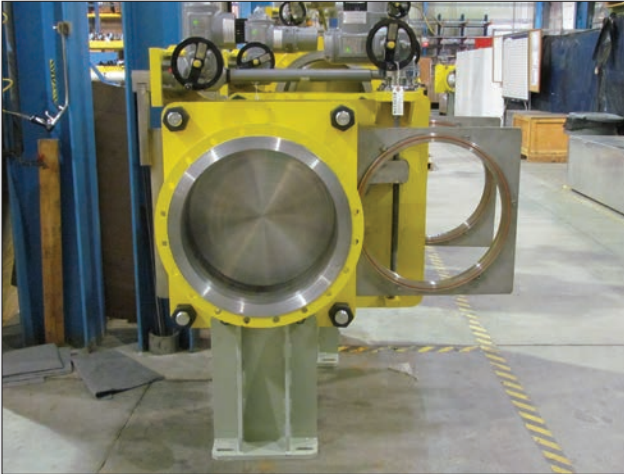

Features

For the sliding type Line Blinds and Goggle Valves, Strahman offers full automation. Automated Blinds are used for applications with very frequent switching operations and/or blinding of dangerous fluids where remote actuation is preferred. The actuation of the Cam system, as well as the Spectacle plate, can be by electric motor, Air Cylinder, Air Motor or Hydraulic. Accessories such as limit switches, solenoid valves, oil cabinets etc. can be included. Just specify your requirement.

Technical Specifications

NOMINAL DIAMETER

- NPS1/2 (DN15) - NPS100 (DN2500)

PRESSURE RATING

- ASME Class 150 to Class 1500
- Other pressure classes up to ASME 2500 are available upon request.

FUNCTION

- Perfect Gas and Liquid Isolation (ZERO Leakage)

TEMPERATURE RANGE

- Standard Design: -20°C ~ +200°C
- High Temp. Design: +200°C ~ +816°C
- Cryogenic Design: -196°C

MATERIALS

- Body: Carbon Steel, Stainless Steel, Special Material (Duplex, Hastelloy, Monel, Inconel, etc.)
- Blind: Stainless Steel, Special Material (Duplex, Hastelloy, Monel, Inconel, etc.)
- Moving Parts & Sealing Surface are Anti-Corrosion Materials

Common Applications

REFINERY

- Ethylene Furnace
- Decoking Line
- Steam & Vapor Line
- Catalyst Service
- Flare Gas Line
- FCCU Fractionator Isolation (overhead & bottom line)

CHEMICAL PLANT

- Reactor Blowdown
- Transfer Line
- Mixing Lines
- Filtration System
- Chemical Cleaning Isolation
- Regeneration Gas Line
- Loading Station

OFFSHORE

- FPSO
- LNG Ship
- Shipboard Lines
- Vessel Inlet
- Inert Gas System

STEEL

- Coke Oven Gas
- Blast Furnace Gas

POWER PLANT

- Coke Oven Gas

Most Extensive Choices for Line Blinds!

FEATURES

- Quick change & easy operation – One operator can blind/unblind up to a 100” pipeline safely by operating the hand wheel.
- Wide range of product applications – Ideal for gas, fuel, solvents, LNG, petroleum products, slurries, powders, chips, and mixing liquids.
- Locking devices – Avoid operational error and unsafe operation.
- Auto positioning of spectacle – Sets the spectacle plate in the correct position each time the blind is thrown.
- Compact designs available.
Ideal for space restrictions – Allows for blinding pipelines where space is limited.
- Unique Cam Gear and seat design – Creates clearance within the Line Blind body without movement of the adjacent piping. Operating our non-spreading design does NOT put any stress in the process pipe, hence avoiding pipe misalignment.

AVAILABLE OPTIONS

- Flanged, Butt Weld, Compact and Enclosed styles
- Available materials: Carbon Steel, 304/304L, 316/316L, Hastelloy, Duplex, Titanium (other materials available on request)
- Wide range of available seal rings and gasket materials for temperatures from cryogenic to 1000°C (1832°F)
- 150 lb., 300 lb. and 600 lb. classes standard
- 900 lb., 1500 lb., and 2500 lb. classes available
- Flanges available to ANSI, DIN, BS, JIS, or special if required
- Fully automated actuation packages available (Electric, Air & Oil actuation)
- Position Indication either mechanical or electronically available
- Special face-to-face or other dimensions possible.
- Both Cast and Fabricated construction available to allow full production flexibility.
- Drain connection on Line Blind available
- Additional drain, purge and sampling valves available
- A wide range of locking devices available
- Spectacle Plate covers available
- Special painting and coatings available
- Double seal ring designs are available
- Outer weights available for balanced rotation of spectacle plate with rotating designs

Common Applications

PETROCHEMICAL

- Catalytic Cracking Units (FCC)
- Delayed Coking Units
- Storage Tanks
- Tank Farms
- Hydro-cracking units
- Gas Flare Applications

CHEMICAL

- Isolation in VCM units
- Isolation in multi-purpose plants
- Acitic Acid, Acrylic Acid, Methyle Acetate
- Ethylene Propylene, HDPE
- Butadine, Naphta, Diesel, Paraxylene

SLURRY

- Cement plants
- Mining (Autoclave gas line isolation H2)

MARINE

- Ships, Tankers (LNG), and Barges
- Cryogenic LNG Applications
- Terminals and storage facilities
- Loading Arms

STEEL MILL

- Isolation of Coke Oven Gas Lines (COG)
- Isolation of Blast Furnace Lines
- General Isolation of Process Pipes & Equipment

Most Extensive Choices for Line Blinds!

DESIGN CODE & CONSTRUCTION

- Design to ASME B16.34 as a standard
- Design to International Standards such as ANSI, DIN, BS, JIS
- In-House Finite Element Analysis
- ASTM F1020-82, Line Blinds for marine applications
- ASME Sec II, Materials
- 8ASME Sec VIII Div I, Construction of pressure valves
- ASME Sec IX, Welding
- ASME B16.34, Standards for Flanges
- ASME B16.5, Pipe Flanges and Flange Fittings
- Both cast and fabricated construction available
- API 598, Valve Inspection & Test

CERTIFICATES & APPROVALS

- ISO 9001 Certified
- PED/CE Marking to Module H
- Russia GOST-R approved
- Russia RTN approved
- Russia TR-CU010 and TR-CU032 certified
- Fire Safe to API 607
- TUV AD 2000 HP 0 Certified
- Certified for Canadian applications
CRN 0C08554.2



Optional Hand Wheel locking



Cam-Gear System Non-Spreading

Please also see our Type 740S and 760S videos at
<https://www.strahmanvalves.com/resource-center-nc/videos/>

Standard Gasket Range

FLAT GASKETS

- PTFE
- Graphite
- Graphite/316
- Graphite/Inconel

O-RINGS

- Viton
- Viton/PTFE Encapsulated
- Nitrile

O-RINGS (continued)

- EPDM
- Silicone
- Silicone/FEP Encapsulated
- Perfluoro Elastomer, Kalrez, Chemrez
- Buna-N
- Ethylene propylene rubber

Application Guide for Sealing Materials

Material/Temperature	Property	Recommended Use	Not Recommended For
Nitrile (Buna-N) -40°C to +135°C Nitrile (Low Temp) -65°C to +120°C	Good resistance to petroleum based oils and fuels, silicone greases, hydraulic fluids, water and alcohols. It has a good balance of working properties such as low compression set, high tensile strength, high abrasion resistance, combined with low cost.	<ul style="list-style-type: none"> • Silicone Greases/Oils • Water • Petroleum Oils/Fuels • Ethylene Glycol Fluids 	<ul style="list-style-type: none"> • Keystones(MEK) • Halogenated Hydrocarbons • Auto/Aircraft Brake Fluids • Strong Acids • Sunlight, Ozone, Weathering • Weathering Phosphate Esters H2S
Viton (Fluorocarbon) -30°C to +204°C	Featuring excellent resistance to petroleum products and solvents, with good high temperature and low compression set characteristics. For use with wide chemical exposure situations, and with low gas permeability, it is also suited for hard vacuum service.	<ul style="list-style-type: none"> • Most Acids/Chemicals • Halogenated • Hydrocarbons • Di-Ester Lubricants • Petroleum Oils/Fuels • Silicone Oils/Greases • Transmission Fluid 	<ul style="list-style-type: none"> • Keystones(MEK) • Auto/Aircraft Brake Fluids • Amines (Ammonia) H2s • Acetone, Skydrol, Ethyl Acetate • Hot Water and Steam • Low Molecular Esters and Ethers
Atlas -30°C to +204°C *reg TM Asahi Glass Co.	Atlas is a unique fluoroelastomer resistant to petroleum oils, steam, hydrogen sulfide and amine corrosion inhibitors. This compound is generally used for sour gas oil field services.	<ul style="list-style-type: none"> • Petroleum Oils • H2S, Steam 	<ul style="list-style-type: none"> • Acetone, Lacquers
EPDM (Ethylene Propylene) -54°C to +150°C	Ethylene Propylene has excellent ozone and chemical resistance characteristics. Generally used in automotive break systems.	<ul style="list-style-type: none"> • Brake Fluids • Refrigerants, Sunlight • Ozone, Weathering • Hot Water and Steam • Auto/Aircraft Brake Fluids 	<ul style="list-style-type: none"> • Petroleum Oils, Fuels • Diester Lubricants
FVMQ (Fluorosilicone) -62°C to +240°C	Fluorosilicone combines the good high and low temperature stability of silicone with the fuel, oil and solvent resistance of fluorocarbon.	<ul style="list-style-type: none"> • Jet Fuel • Dry Heat, Wide Temp. Range • Petroleum Oils • Chlorinated Solvents • Gasoline 	<ul style="list-style-type: none"> • Keystones(MEK) • Auto/Aircraft Brake Fluids • Amines (Ammonia) • Acetone, Ethyl Acetate • Phosphate Esters • Some Acids
Highly Saturated Nitrile (HSN, HNBR) -26°C to +160°C	A nitrile elastomer with excellent resistance to petroleum oils and sour gas. With the extended temperature range, HSN is becoming a preferred compound in the oil patch.	<ul style="list-style-type: none"> • Petroleum Oils • HS2, CO2 	<ul style="list-style-type: none"> • Brake Fluid
Neoprene -40°C to +135°C	Due to its excellent resistance to freon and ammonia, Neoprene is widely accepted as a preferred elastomer for refrigeration seals.	<ul style="list-style-type: none"> • Refrigerants, Alcohol, Ozone, Ammonia • Petroleum Oils • Dilute Acids • Silicone Ester Lubricants 	<ul style="list-style-type: none"> • Petroleum Oils, Toluene • Keystones (MEK) • Gasoline, Auto/Aircraft Brake Fluid
Polyurethane -50°C to +105°C	An excellent elastomer with high abrasion resistance characteristics and high tensile strength. Used in high pressure hydraulic systems where highly stressed parts are subject to wear.	<ul style="list-style-type: none"> • Petroleum Oils • Hydraulic Oils • Some Hydrocarbon Fuels • Oxygen/Ozone • Drive Belts 	<ul style="list-style-type: none"> • Keystones (MEK) • Acids • Auto/Aircraft Brake Fluids • Chlorinated Hydrocarbons • Water

Application Guide for Sealing Materials

(continued...)

Material/Temperature	Property	Recommended Use	Not Recommended For
Silicone (VMQ) -65°C to +240°C	Silicone elastomer is resistant to high, dry heat in primarily static applications. It has low compression set characteristics and wide temperature range.	<ul style="list-style-type: none"> • Dry Heat, Alcohol, Vegetable Oil • Wide Temp. Range • Sunlight/Ozone, Weathering • Odorless and Non-Toxic 	<ul style="list-style-type: none"> • Keystones (MEK) • Acids • Silicone Oils • Brake Fluids • Petroleum Oils & Fuels
Teflon (PTFE) -40°C to +240°C	Excellent chemical resistant, Teflon is a tough, chemically inert elastomer processing an incredible working range. For static and slow intermittent dynamic situations. Teflon is hampered only by its poor memory at low temperature.	<ul style="list-style-type: none"> • Most Chemical Resistance • Fuel Resistance • Low Coefficient of Friction 	<ul style="list-style-type: none"> • Non-Elastic
FFPM/FFKM (Chemraz, Kalrez, Simriz Perfluoroelastomer) ~ +323°C	Excellent chemical resistant, temperature resistant elastomer. Various compounds designed for specific applications.	<ul style="list-style-type: none"> • High Temperature Resistance • Excellent Chemical Resistance • Low Out Gassing Chlorine • Wet/Dry Petroleum Oil • Chlorinated Hydrocarbons 	<ul style="list-style-type: none"> • Molten Metals • Gaseous Alkali Metals • Halogenated Freons/Fluids • Uranium Hexafluoride
FEPV/PFAV (Teflon Encapsulated O-Ring) -40°C to +260°C	Covered with Teflon tube, usually Silicone or Viton. Good wear resistance and good permeation resistance.	<ul style="list-style-type: none"> • Most Chemical Resistance • Fuel Resistance • Low Coefficient of Friction • Heat Resistance 	<ul style="list-style-type: none"> • Depends on O-ring Care
Graphite (Pure, Engineered) -240°C to +800°C	Excellent chemical stability and wide range of temperature, extreme low and high.	<ul style="list-style-type: none"> • Most Chemical Resistance • Heat Resistance 	

Customer Selection Guide

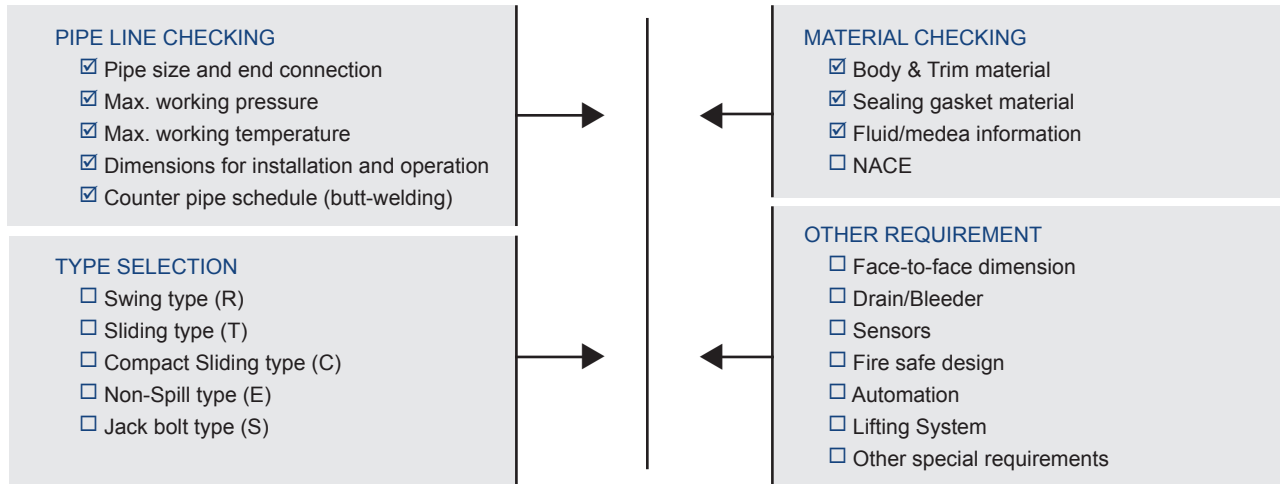

Product Coding System

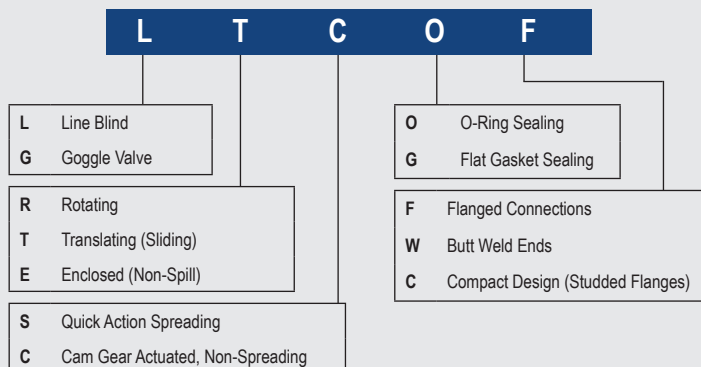

FKM

FKM/FPM	VITON
NBR/HNBR	NITRIL RUBBER, BUNA-N
FEPV/PFAV/PFAS	TEFLON ENCAPSULATED O-RING
VMQ/FVMQ	SILICONE, FLUORSILICONE
EPDM	ETHYLENE PROPYLENE RUBBER
FFKM/FFPM	PERFLUOROELASTOMER, KALREZ, CHEMREZ
GR	GRAPHITE
M	METAL

THE STRAHMAN FAMILY OF PRODUCTS INCLUDE

Wash Down Equipment

Strahman offers a full line of mixing units, hose stations, hoses, nozzles, and wash down accessories. Our wash down line is designed for industrial use and is used in a wide variety of industries including food, beverage, pharmaceutical, chemical and other applications.

Pre-Rinse Equipment for Commercial Kitchens

Strahman offers pre-rinse spray nozzles, handles, hoses, hose reels and Pivot Pro swivel connectors. Designed for use in restaurants, hotels, supermarkets, and all commercial kitchens, food serving and food preparation applications.

Sampling Valves

Strahman has a full line of sampling valves that produce live samples without exception. Our sampling valves' unique design prevents failure caused by sediment or clogging.

Drain Valves

Strahman Drain Valves are designed to prevent clogging. They are ideal for use in liquid and gas service or with slurries, polymers, and high viscosity fluids that tend to solidify at room temperature.

Automated Valves and Fire Safe Products

Strahman automated valve packages with floating ball valves and resilient seated butterfly valves come complete with electric or pneumatic actuators for a wide array of industrial applications. Additionally, a full suite of API 607 fire safe valve products are offered as actuated units or to be used in conjunction with our FM approved thermal shut-off assemblies. Resettable Emergency Block Valves (R-EBV) are also available for the oil & gas and chemical industries.



ISO 9001
Multi-site certified



EST. SINCE 1921

STRAHMANVALVES.COM

WORLD HEADQUARTERS

STRAHMAN VALVES, INC.

2801 BAGLYOS CIRCLE, BETHLEHEM, PA 18020

P: 484.893.5080 F: 484.893.5099 E: STRAHMAN@STRAHMAN.COM

FRANCE

STRAHMAN VALVES, INC.

SAVOIE HEXAPOLE

F-73420 MERY, FRANCE

P: 33 (0) 479.357800

F: 33 (0) 479.357820

E: SALESFR@STRAHMAN.COM

GERMANY

STRAHMAN VALVES, INC.

ALLERHEILIGENSTR. 69

D-77855 ACHERN, GERMANY

P: 49 (0) 7841.68465.30

F: 49 (0) 7841.68465.31

E: EMRAZEK@STRAHMAN.COM

CHINA

STRAHMAN VALVES, INC.

RM 701, NO 5, LANE 333

LAIFANG RD, JIUTING, SONGJIANG

SHANGHAI, 201615, CHINA

P/F: 86 (0) 21.5767.6998

C: 86 (0) 189.1751.7369

E: ROBIN.SUN@STRAHMAN.COM



A DIVISION OF STRAHMAN VALVES, INC.

BITORQ.COM

PO BOX 309

1N050 LINLAR DRIVE

LA FOX, IL 60147 USA

P: 630.208.9343

F: 630.232.6235

E: SALES@BITORQ.COM

PVLB022020