



# THERMAL SHUT-OFF VALVES FLP - HT SERIES

INSTALLATION, OPERATION & MAINTENANCE



# GENERAL INFORMATION

## OVERVIEW

BI-TORQ Valve Automation® Thermal Shut-Off Valves (TSVs) are designed for flow shut-off protection in piping systems handling flammable gasses, liquids, solvents, toxic fluids, or any other potentially dangerous media. These fire control valves terminate flow in the event of fire, aiding in reducing fire intensity. In the event of fire, the fusible link separates, allowing the top mounted spring pack to drive an API 607 fire-safe rated valve into a closed position. Fusible links are available in a range of temperature settings. The TSVs also are available in a fail open position, ideal for a fire suppression system in the event of a fire.

The TSVs you have received have been assembled and tested at our factory with attention to safety in mind. BI-TORQ Valve Automation® uses high quality materials and tested engineering to ensure that this product will operate safely and reliably. Carefully read all instructions before handling in order to avoid injury to the operator or damage to the product.

**NOTE: PLEASE REFER TO ASSEMBLY DRAWING FL-HD-0600 FOR PARTS IDENTIFICATION AND A COMPLETE PARTS LIST.**

## GENERAL SAFETY INSTRUCTIONS



**WARNING: USE EXTREME CAUTION IN HANDLING THE ASSEMBLY BECAUSE THE SPRING PACK IS UNDER FULL TENSION AT ALL TIMES.**

**NOTE: BALL AND BUTTERFLY VALVES ARE SHIPPED IN THE CLOSED AND UNARMED POSITION WITH THE DECLUTCH GEAR IN THE ENGAGED POSITION.**

The unit must be installed in a location with carefully maintained ambient temperatures. Installing the link in locations where high temperature fluctuations are possible (such as direct sunlight) is not recommended. Exposure to high ambient temperatures can cause the fusible links to break prematurely. (See Table 1 for link temperature ratings).

LINK SERIES	PART NO.	YIELD TEMP	MAX AMBIENT TEMP
FL-1	FL-1-165	165° F (74° C)	135° F (57° C)
FL-1	FL-1-212	212° F (100° C)	185° F (82° C)
FL-1	FL-1-286	286° F (141° C)	253° F (123° C)
FL-1	FL-1-360	360° F (182° C)	330° F (166° C)
K LINK	314165	165° F (74° C)	135° F (57° C)
K LINK	314212	212° F (100° C)	185° F (82° C)
K LINK	314280	280° F (138° C)	253° F (123° C)
K LINK	314360	360° F (182° C)	330° F (166° C)

TABLE 1 PLEASE CONSULT FACTORY FOR SPECIAL ORDER LINKS.



FIG. 1A FL-1 LINK FOR  
SPRING PACK 109-020  
(6 PER UNIT)



FIG. 1B K LINK FOR  
SPRING PACK 129-020  
(6 PER UNIT)

## INSTALLATION ARMING THE HT SERIES ASSEMBLY



**IMPORTANT:** ALL ASSEMBLIES ARE SHIPPED WITH THE VALVE IN THE CLOSED POSITION. UNITS ARE PROPERLY ARMED WHEN FUSIBLE LINKS ARE INSTALLED AND DECLUTCH GEAR IS DISENGAGED.

**NOTE: INSTALL VALVE IN PIPELINE BEFORE PROCEEDING!**

**REQUIRED TOOLS: NONE**

1. Confirm the declutch mechanism on manual override gear is in the engaged position. (See Section VI on page 6 for full instructions on declutch operation). Refer to drawing FL-HT-0600-1.4 (Fig. 2) for engaged/disengaged declutch positions.
2. Remove all links from arming assembly and move pivot arm out of the way (CCW).



**IMPORTANT:** TURNING HANDWHEEL WHILE LINKS ARE SECURE TO UNIT WILL STRIP ARMING ASSEMBLY.

3. Keeping the gear override in the engaged position, turn the declutch gear handwheel toward the open position (CCW) until it stops.
4. Remove the top nuts on link retaining studs #8 on FL-HT-0600 (Fig. 3) that hold links.
5. Reposition and secure fusible link(s) (Fig. 1A or 1B) on link retaining studs with the top nuts until link s held firmly in position.



**CAUTION:** HAND-TIGHTEN ONLY! TIGHTENING WILL STRESS THE LINKS AND COULD RESULT IN IMPROPER FUNCTIONING.

6. Turn handwheel CW (approx. 1 revolution) until links hold spring tension and no resistance is felt on handwheel (**DO NOT OVER TURN**)
7. Move declutch mechanism into the disengaged position. The handwheel will spin freely when properly disengaged.
8. Unit is now armed.

**NOTE: HANDWHEEL MAY NEED TO BE TURNED SLIGHTLY CCW OR CW TO MOVE THE DECLUTCH LEVER INTO THE PROPER LOCKED POSITION.**



**IMPORTANT:** THE UNIT IS NOT ARMED UNTIL THE GEAR HAS BEEN DISENGAGED AFTER INSTALLATION OF LINKS. IF THE GEAR IS LEFT IN THE ENGAGED POSITION THE VALVE WILL NOT SPRING CLOSE.

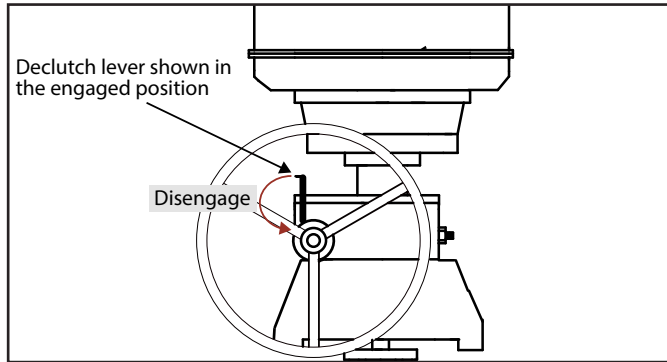

FIG. 2 FL-HT-0600-1.4

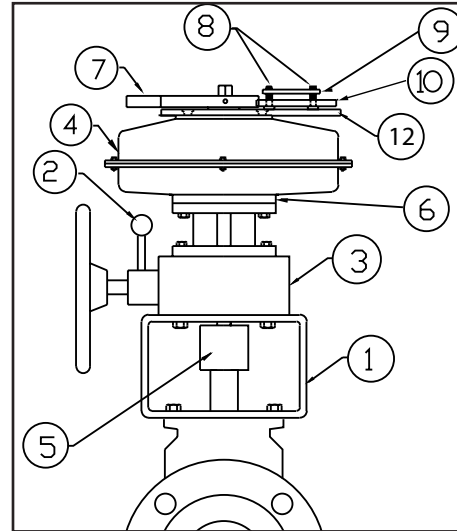

FIG. 3 ASSEMBLY DRAWING FL-HT-0600

## MANUAL OPERATION (AFTER INSTALLATION AND ARMING)

The valve may be operated closed-open in the normal manner using the declutchable gear handwheel **ONLY** upon removal of the fusible links.



**IMPORTANT:** FAILURE TO REMOVE FUSIBLE LINKS PRIOR TO OPERATING VALVE WILL DAMAGE THE ASSEMBLY.

1. Move the declutch mechanism in the engaged position.
2. Turn handwheel CCW until it stops and tension on the links is relieved.
3. Remove the top nuts on link retaining studs. They should be finger tight.
4. Remove links and store in a safe place.
5. Turn handwheel CW until it stops, closing the valve.

**NOTE:** HANDWHEEL MAY NEED TO BE TURNED SLIGHTLY CCW OR CW TO MOVE THE DECLUTCH LEVER INTO THE PROPER LOCKED POSITION.



**CAUTION:** FAILURE TO RETURN THE GEAR TO THE DISENGAGED POSITION AFTER MANUAL OPERATION IS COMPLETED WILL LOCK THE GEAR AND VALVE INTO POSITION, AND THE FUSIBLE LINK ASSEMBLY WILL NOT FUNCTION PROPERLY. .



**IMPORTANT:** THE FUSIBLE LINKS MUST BE RETURNED TO THEIR ORIGINAL POSITION AFTER MANUAL OPERATION.

## OPERATING THE DECLUTCHABLE MANUAL OVERRIDE GEAR



**IMPORTANT:** MAKE SURE THAT THE FUSIBLE LINKS HAVE BEEN REMOVED BEFORE ATTEMPTING TO OPERATE THE VALVE WITH THE DECLUTCHABLE MANUAL OVERRIDE.

Use the following instructions to **ENGAGE** the declutchable manual override.

1. Using one hand, grab the override engagement handle, squeezing the bottom and top handle together.
2. With the handles still squeezed together, rotate the handle from its declutched position upward toward the spring pack mounting flange until the handle locking tabs are in line with their locking positions.

**NOTE: IN SOME CASES THE OVERRIDE GEAR TEETH WILL NOT MESH CORRECTLY WHEN ROTATING THE HANDLE UPWARD. IF THIS OCCURS, ROTATE THE OVERRIDE HANDWHEEL SLIGHTLY TO MESH THE GEARS AND THEN ROTATE THE DECLUTCH HANDLE UPWARD.**

3. Once the override handle is in its locked position, the override is ready to be used. Clockwise rotation of the override handwheel will produce clockwise rotation of the override output and valve. Conversely, counterclockwise rotation of the handwheel will produce counterclockwise rotation of the override output, and valve.

Use the following instructions to **DISENGAGE** the declutchable manual override.

**NOTE: WHEN THE ASSEMBLY IS REARMED WITH THE FUSIBLE LINKS BACK IN PLACE, THE MANUAL OVERRIDE MUST BE RETURNED TO ITS DECLUTCHED POSITION. REVERSING THE PROCEDURE ABOVE WILL RETURN THE OVERRIDE TO THE DECLUTCHED POSITION. MAKE SURE THAT THE HANDLE LOCKING TABS ARE INSERTED INTO THEIR LOCKING POSITION ON THE OVERRIDE HOUSING.**

Leaving the declutch engaged will prohibit the spring return unit from cycling the valve to the closed position when the fusible links yield. Leaving the unit in the engaged position will prevent the unit from operating correctly, may cause damage to the override as well as drivers linkages, etc. and void the override warranty.



**IMPORTANT:** THE FUSIBLE LINKS WILL HAVE TO BE REINSTALLED AND THE DECLUTCH DISENGAGED BEFORE THE ASSEMBLY IS PROPERLY ARMED. THE FUSIBLE LINK ASSEMBLY WILL NOT FUNCTION PROPERLY. .



THE PICTURE ON THE LEFT SHOWS THE DECLUTCH OPERATOR IN THE "DISENGAGED" POSITION TO ALLOW THE SPRING PACK TO CLOSE THE VALVE WHEN THE FUSIBLE LINKS YIELD. AS SHOWN, THE HANDLE ARRANGEMENT IS PINNED IN THE DOWN POSITION. THE HANDWHEEL SHOULD ROTATE FREELY IN EITHER THE CLOCKWISE OR COUNTERCLOCKWISE DIRECTIONS WITHOUT AFFECTING THE VALVE ROTATION.



THE PICTURE ON THE LEFT SHOWS THE DECLUTCH IN THE "OVERRIDE" POSITION, OR "ENGAGED," FOR OPERATING THE VALVE MANUALLY. AS SHOWN, THE HANDLE ARRANGEMENT IS PINNED IN THE UP POSITION FOR OVERRIDE. ROTATION OF THE HANDWHEEL CLOCKWISE WILL ROTATE VALVE CLOCKWISE (GENERALLY CLOSED DIRECTION); ROTATION OF THE HANDWHEEL COUNTER-CLOCKWISE WILL ROTATE ACTUATOR COUNTERCLOCKWISE (GENERALLY OPEN).



**IMPORTANT:** FUSIBLE LINKS MUST BE REMOVED BEFORE ATTEMPTING TO OPERATE THE VALVE WITH THE DECLUTCH. .

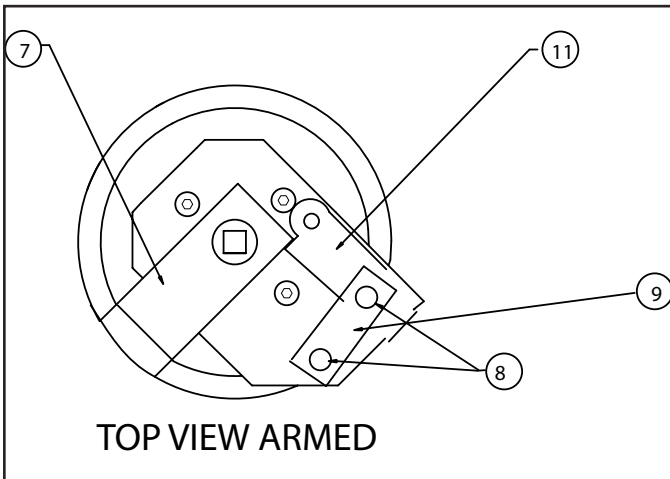

FIG. 4 FL-HT-0600-1.1

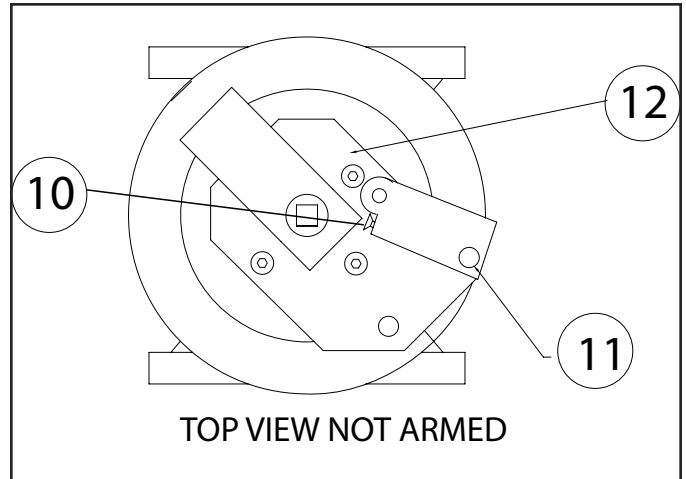

FIG. 5 FL-HT-0600-1.2

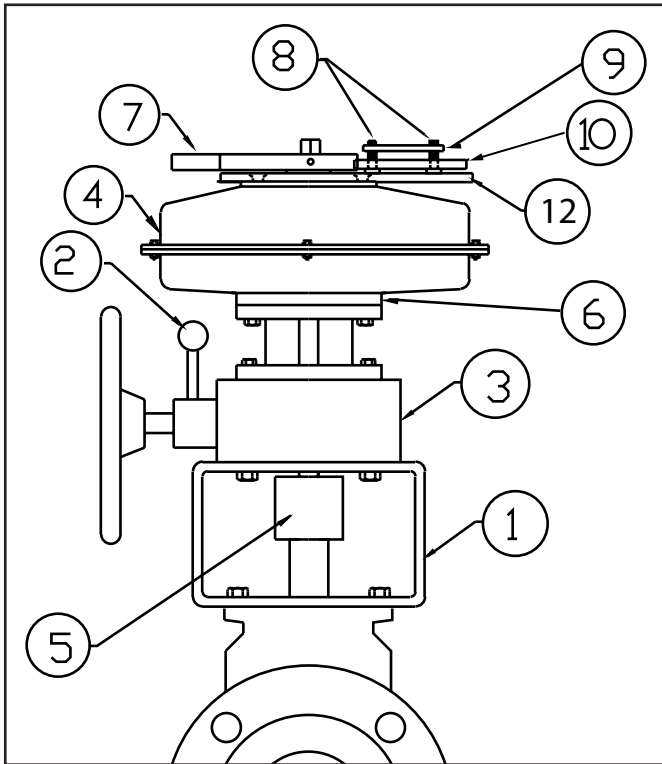

FIG. 6 ASSEMBLYDRAWING FL-HT-0600

1	MOUNTING BRACKET	7	SPRING PACK KEEPER LEVER
2	DECLUTCH LEVER	8	LINK HOLDING STUDS
3	DECLUTCHABLE GEAR OPERATOR	9	FUSIBLE LINKS (FIG. 1A OR FIG. 1B)
4	SPRING PACK (109 OR 129)	10	OPEN POSITION ADJUSTMENT STOPS
5	VALVE ADAPTER	11	PIVOT ARM
6	SPRING PACK MOUNTING PLATE (129 SPRING PACK ONLY)	12	MOUNTING PLATE FOR FUSIBLE LINK

TABLE 2 PARTS

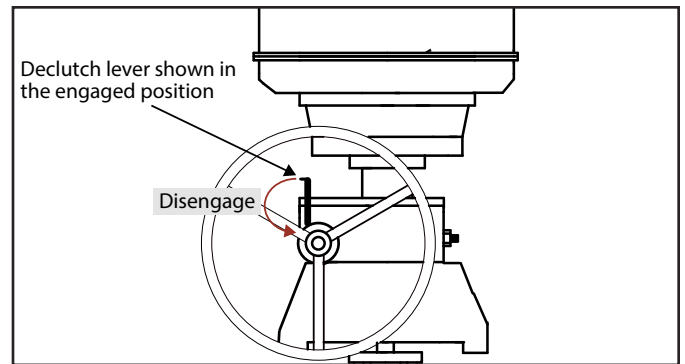

FIG. 7 FL-HT-0600-1.4

## MAINTENANCE



**IMPORTANT:** THE FUSIBLE LINK MANUFACTURER RECOMMENDS ANNUAL REPLACEMENT OF LINK(S) AS PART OF A REGULAR MAINTENANCE SCHEDULE.

Contact your local distributor or Strahman Group for replacement links. Order by part number or temperature rating on old link. To change out links, engage the declutch mechanism and follow the arming procedure outlined in **Arming the HT Series Assembly** section. Replacement valve seats and seals subject to normal wear are also available from your local distributor or contact Strahman Group directly.

The spring case and declutchable gear are lifetime lubricated and do not require maintenance. Disassembly of the spring case or gear will void any written or verbal warranties.



**WARNING: THE SPRING CASE CLOCKSING IS ALWAYS UNDER PRESSURE. DO NOT DISASSEMBLE SPRING PACK UNDER ANY CIRCUMSTANCES. DISASSEMBLY OF THE SPRING PACK COULD RESULT IN SERIOUS INJURY OR DEATH.**

## THE STRAHMAN FAMILY OF PRODUCTS INCLUDE:



### WASH DOWN EQUIPMENT

Cleaning and sanitizing equipment for applications where safety is the number one concern — built to outlast and outperform all others.

### AUTOMATED VALVES & THERMAL SHUT-OFF VALVES

Completely assembled automated valves and fire-safe thermal shut-off valves fabricated for quick and reliable problem-solving solutions for industrial applications.

### VALVES & LINE BLINDS

Engineered solutions for the transfer of fluid and flow control for highly critical applications from sampling to inline process to permanent isolation.





© STRAHMAN GROUP | PUBLISHED 12.09.22

## CONTACT US

Need more information? Give us a call today or visit our website.

 877-787-2462  
484-893-5080

 2801 Bagylos Circle  
Bethlehem, PA 18020

 [StrahmanGroup.com](http://StrahmanGroup.com)



PRECISION AND PERFORMANCE